

HEX 系列重载防爆开关 (EEX)

产品特性

- 坚固的铸铝壳体, 适用于极其恶劣的环境
- 符合 EN 60947-5-1, IEC 60947-5-1, UL508, NEMA250, CSA22.2 标准
- 多种可选的执行器
- 重复精度高(0.03mm 线性)

电气参数

IEC 60947-5-1 / EN 60947-5-1							
电气额定值 和使用类别	不同额定电压下的额定工作电流					控制容量	
	120V	240V	380V	480V	600V	接通	分断
AC15 A600	6	3	1.9	1.5	1.2	7200	720
DC13 Q300	125VDC 250VDC					69	69
	0.55 0.27						

产品规格

操作速度	0.05mm-2m/sec
额定电压/电流	10A/600V AC (EN60947-5-1) AC15 A600 / DC13 Q300
寿命	机械 1000万次 (最少) 电气 100万次 (最少)
环境温度	-28.9~+85°C (-20~185°F)
耐振动	25gn (10..150 Hz, 11ms) per IEC60068-2-6
耐冲击	60gn (9ms) per IEC 60068-2-27
绝缘强度	2200VAC 持续1分钟
短路保护	10A fuse
终端线	12-22AWG (2.05-0.644mm ²)
保护等级	IP 67 依照 IEC 60529, NEMA Types 2, 4, 6, 6P, 12, 13
HES 适用危险场地:	CLASS I DIV GROUPS B,C,D CLASS II DIV GROUPS E,F,G

* 可以提供超低温, 高温款式。请和我们联系



选型指南:

HEX

1

接点形式

- 1: SPDT (1NO/1NC) 快动
- 2: DPDT (2NO/2NC) 快动
- 3: DPDT (2NO/2NC) 两级动作
- 4: DPDT (2NO/2NC) 左右分别动作
- 5: DPDT (4NO) 慢动
- 6: DPDT (3NO/1NC) 慢动
- 7: DPDT (2NO/2NC) 慢动
- 8: DPDT (1NO/3NC) 慢动
- 9: DPDT (4NC) 慢动

A

出线孔

- A: 1/2NPT
- F: 3/4NPT

04

执行机构

两位数字或
两位数字加一个字母

A

杆臂形式

- B: 标准
- A: 高精度
- N: 轻动作力
- D: 高精度轻动作力
- C: 保持式
- TB: 左右分别动作
- TA: 左右分别动作(高精度)

F

橡胶密封

- 空白: 标准
- F: 氟橡胶

杆臂直径

- 空白: 11.0mm
- (AB): 8.0mm
- (CH): 7.0mm
- (HW): 7.3mm

HEX 系列重载防爆开关 (EEX)

柱塞式



HEX-1A

1NO/1NC

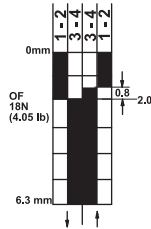
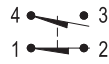

HEX-2A

2NO/2NC

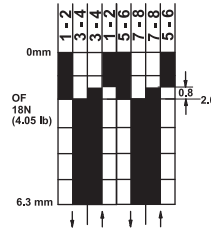
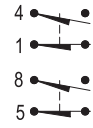

HEX-3A

2NO/2NC(两级动作)

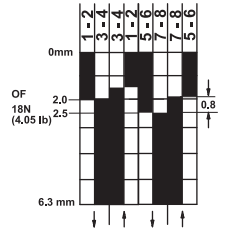
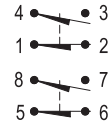

* 注: 01款的动作力是 31.1N (7 lb)

侧柱塞式

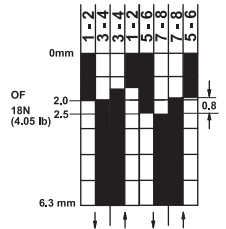
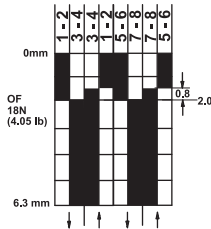
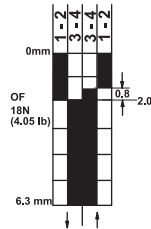

侧柱塞式 (保持式)

10H 型

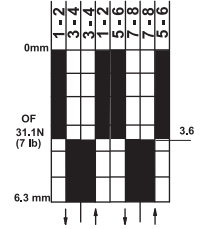
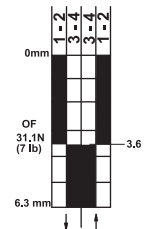

盘簧式

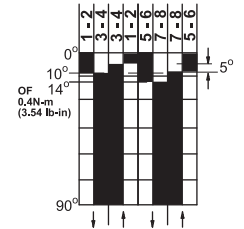
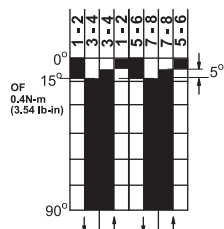
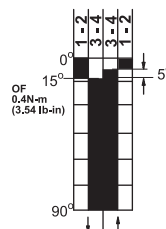

细盘簧式

68 型

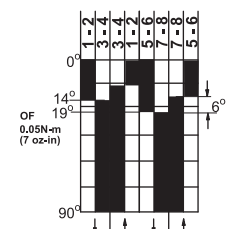
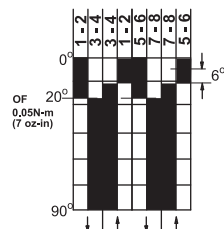
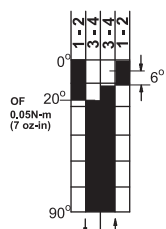

HEX 系列重载防爆开关 (EEX)

转动式头部行程动作图:

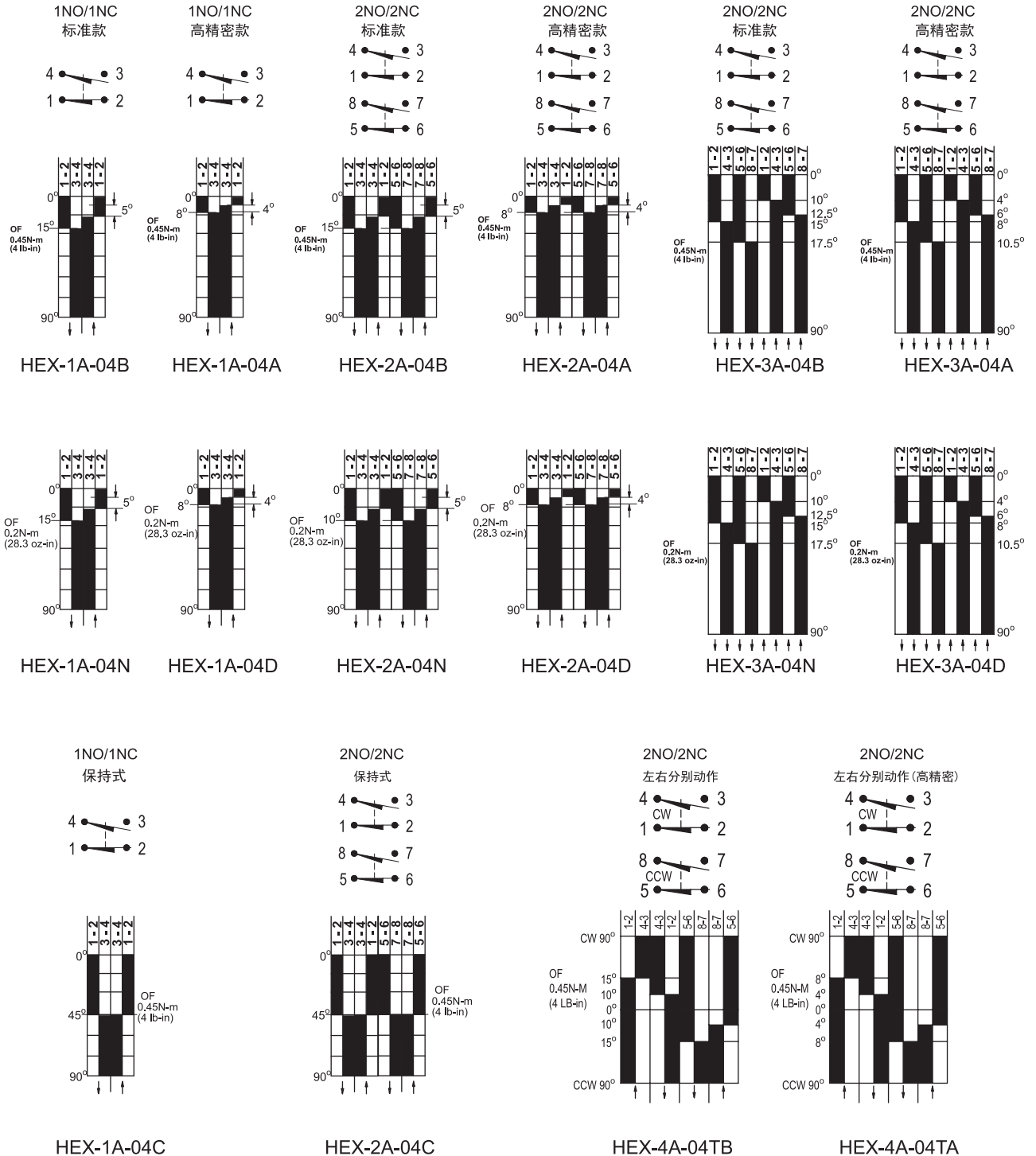

HEX 系列重载防爆开关 (EEX)

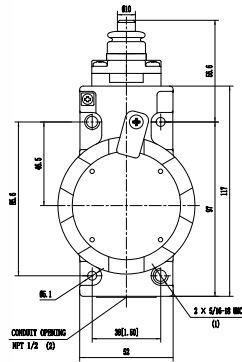

型号

HEX-1A-11: 1NO/1NC
 HEX-2A-11: 2NO/2NC
 HEX-3A-11: 2NO/2NC (两级动作)

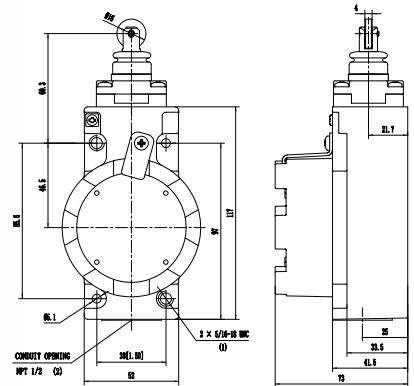

型号

HEX-1A-12: 1NO/1NC
 HEX-2A-12: 2NO/2NC
 HEX-3A-12: 2NO/2NC (两级动作)

动作位置(OP)可调

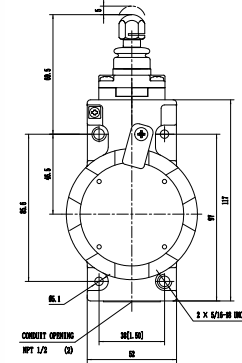

型号

HEX-1A-13: 1NO/1NC
 HEX-2A-13: 2NO/2NC
 HEX-3A-13: 2NO/2NC (两级动作)

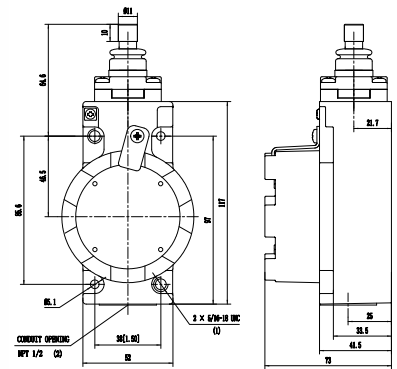

型号

HEX-1A-01: 1NO/1NC
 HEX-2A-01: 2NO/2NC
 HEX-3A-01: 2NO/2NC (两级动作)

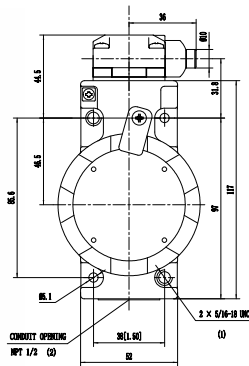

型号

HEX-1A-11H: 1NO/1NC
 HEX-2A-11H: 2NO/2NC
 HEX-3A-11H: 2NO/2NC (两级动作)

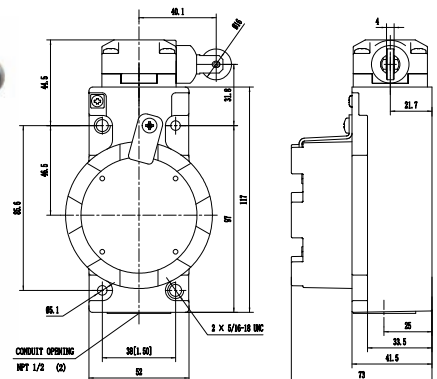

型号

HEX-1A-12H: 1NO/1NC
 HEX-2A-12H: 2NO/2NC
 HEX-3A-12H: 2NO/2NC (两级动作)

* 注: 用户可将滚轮调为水平方向

HEX 系列重载防爆开关 (EEX)

保持式

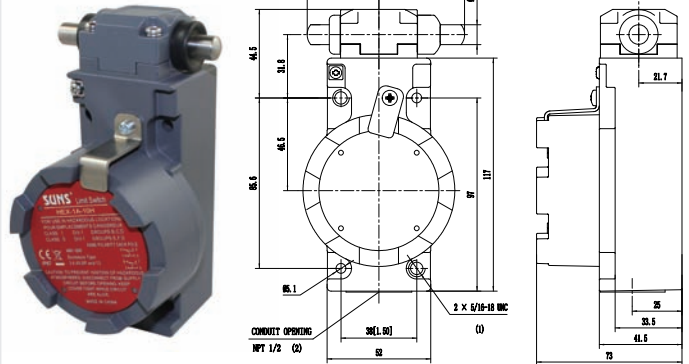
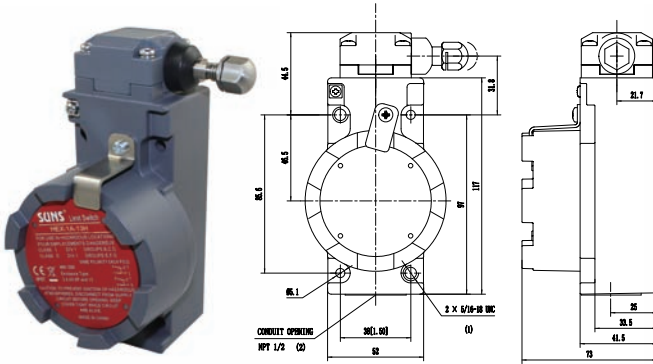

型号

HEX-1A-13H: 1NO/1NC
 HEX-2A-13H: 2NO/2NC
 HEX-3A-13H: 2NO/2NC (两级动作)

型号

HEX-1A-10H: 1NO/1NC
 HEX-2A-10H: 2NO/2NC

全向4位置保持式

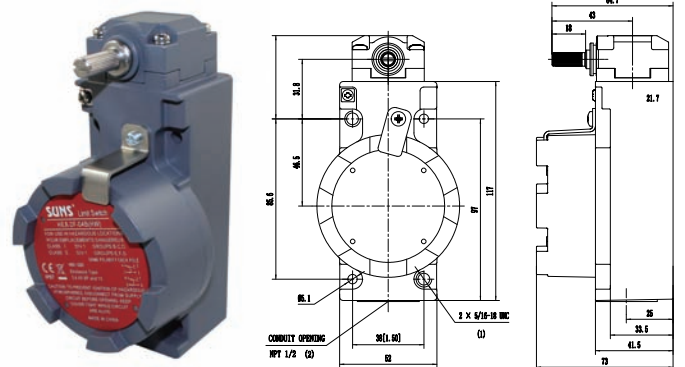
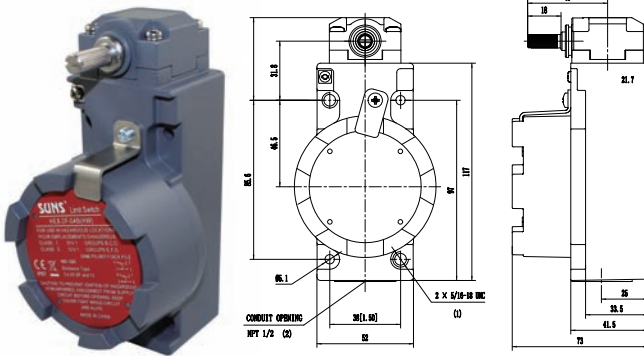

型号

HEX-2A-04C: 2NO/2NC

型号

HEX-1A-04B: 1NO/1NC 标准型
 HEX-1A-04A: 1NO/1NC 高精密型
 HEX-1A-04N: 1NO/1NC 轻动作力型
 HEX-1A-04D: 1NO/1NC 高精密, 轻动作力型
 HEX-2A-04B: 2NO/2NC 标准型
 HEX-2A-04A: 2NO/2NC 高精密型
 HEX-2A-04N: 2NO/2NC 轻动作力型
 HEX-2A-04D: 2NO/2NC 高精密, 轻动作力型
 HEX-3A-04B: 2NO/2NC 标准型(两级动作)
 HEX-3A-04A: 2NO/2NC 高精密型(两级动作)
 HEX-3A-04N: 2NO/2NC 轻动作力型(两级动作)
 HEX-3A-04D: 2NO/2NC 高精密, 轻动作力型(两级动作)

左右分别动作

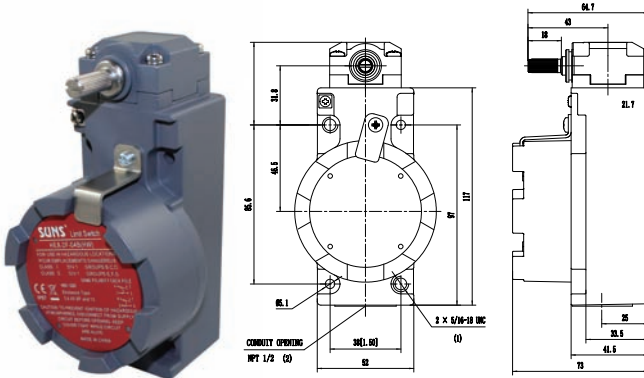

型号

HEX-4A-04TA: 2NO/2NC (高精密型)
 HEX-4A-04TB: 2NO/2NC

头部出厂设置: 顺时针和逆时针都触发开关。用户可以卸下头部, 拉出头部机构, 旋转到需要的相应指示。可实现只是顺时针或逆时针方向触发开关。

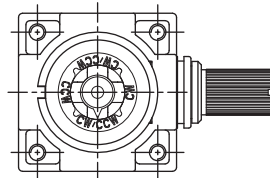

HEX 系列重载防爆开关 (EEX)

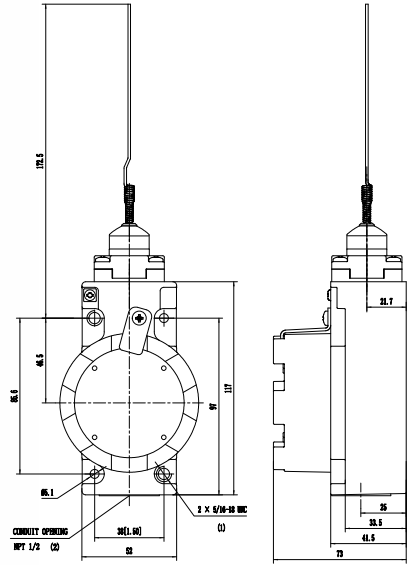
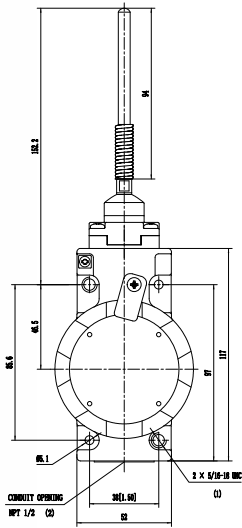

型号

- HEX-1A-66: 1NO/1NC
- HEX-2A-66: 2NO/2NC
- HEX-3A-66: 2NO/2NC (两级动作)

型号

- HEX-1A-68: 1NO/1NC
- HEX-2A-68: 2NO/2NC
- HEX-3A-68: 2NO/2NC (两级动作)

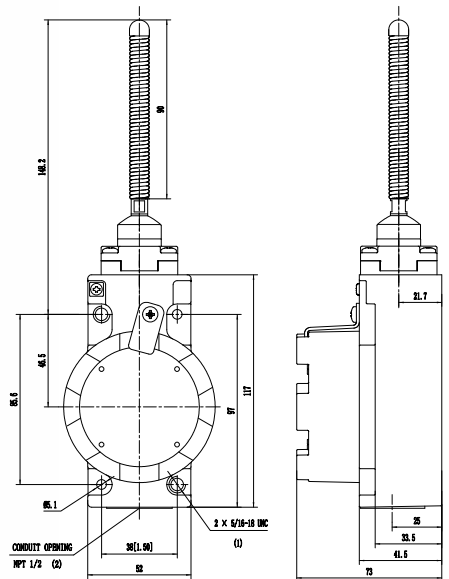
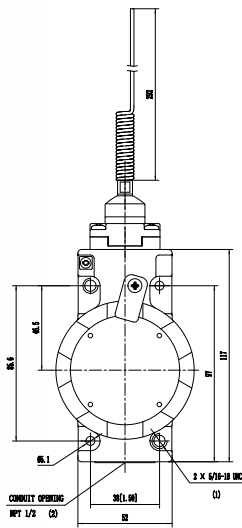

型号

- HEX-1A-69: 1NO/1NC
- HEX-2A-69: 2NO/2NC
- HEX-3A-69: 2NO/2NC (两级动作)

型号

- HEX-1A-00: 1NO/1NC
- HEX-2A-00: 2NO/2NC
- HEX-3A-00: 2NO/2NC (两级动作)

HEX 系列重载防爆开关 (EEX)

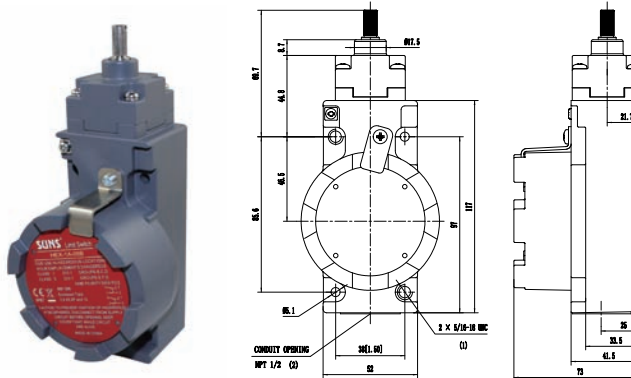
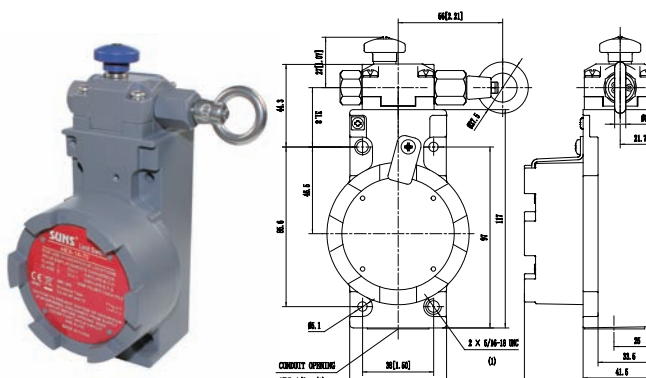
 <p>Technical drawings for the HEX 1A-05B switch, including a perspective view, a front view with dimensions (46.7, 46.3, 46.5, 46.5, 46.1, 25, 38.1, 41.6, 25, 21.7), and a side view. Labels include 'CONDUIT OPENING NPT 1/2" (G)', '38.1 (H)', and '2 X 1/2" (H) (H)'. A red label on the switch shows 'SUNS' and 'EEX'.</p>	 <p>Technical drawings for the HEX 6A-70 switch, including a perspective view with a ring handle, a front view with dimensions (46.7, 46.3, 46.5, 46.5, 46.1, 25, 38.1, 41.6, 25, 21.7), and a side view. Labels include 'CONDUIT OPENING NPT 1/2" (G)', '38.1 (H)', and '2 X 1/2" (H) (H)'. A red label on the switch shows 'SUNS' and 'EEX'.</p>
<p>型号</p> <p>HEX-1A-05B: 1NO/1NC HEX-2A-05B: 2NO/2NC HEX-3A-05B: 2NO/2NC (两级动作)</p>	<p>型号</p> <p>HEX-6A-70: 3NO/1NC HEX-7A-70: 2NO/2NC HEX-8A-70: 1NO/3NC</p>